



MODEL 1000 Interface Specification

**Model : MODEL 1000
(Cash Dispensing Unit)**

Total Page : 17 Page (including cover)

**Date : 2005. 9
Version : V3.3T(INT)**

= Contents =

1. Preview

2. Components

2-1. Frame Format

2-2. Definition of Interface between HOST and MODEL 1000

2-3. Definition of Timing

2-4. Command Format

2-5. Response Format

1. Preview

The document includes the interface specification between MODEL 1000 and the HOST, which make use of serial communication to transfer commands and responses. Each command has to match the response to the signal and for the communication process, the status of FRAME, which is normal or abnormal, should be sent.

2. Components

2.1 Frame Format

This defines interface standard between HOST and MODEL 1000.

2.1.1 The basic DATA FORMAT is like below.

Command Protocol

E	I	S	C	DATA	E	B
O		T	M		T	C
T	D	X	D		X	C

Response Protocol

S	I	S	C	DATA	E	B
O		T	M		T	C
H	D	X	D		X	C

2.1.2 BCC of command protocol is determined by "XOR" for the values from EOT to ETX.

2.1.3 BCC of response protocol is determined by "XOR" for the values from SOH to ETX.

2.1.4 Assignment of Value

SOH	-	01H	STX	-	02H
ETX	-	03H	EOT	-	04H
ACK	-	06H	NCK	-	15H
ID	-	50H			

2.2 Definition of Interface between HOST and MODEL 1000

2.2.1 Basic communication is performed like below

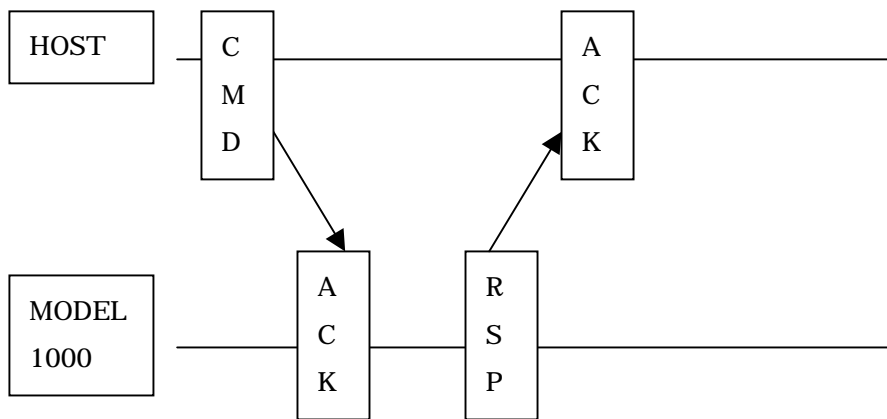

2.2.2 Troubling in HOST COMMAND

The data of HOST COMMAND could be damaged by communication error or BCC ERROR could happen.

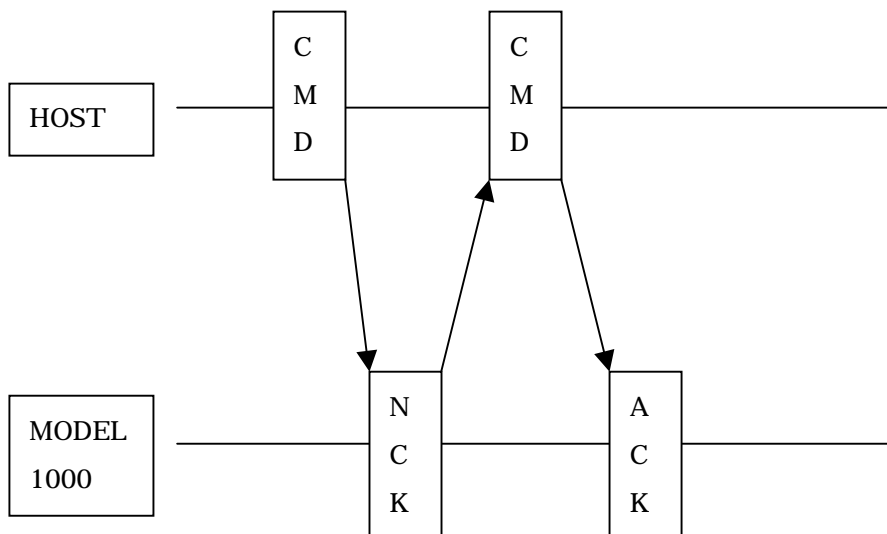

2.2.3 Troubling in RESPONSE COMMAND

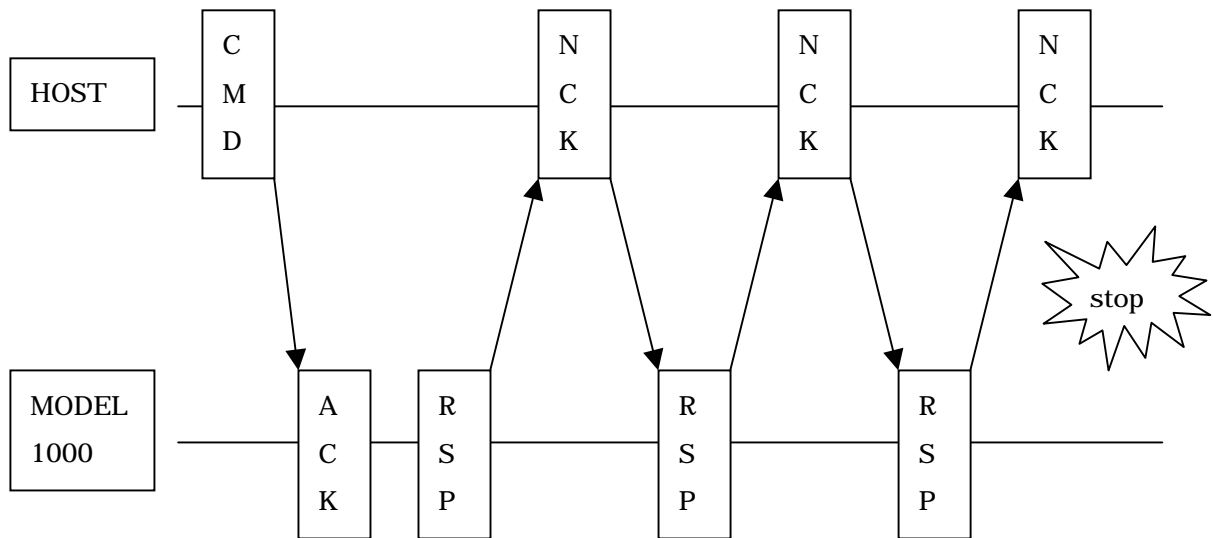

NCK could be sent even 3 times for the RESPONSE, but in this case, the transaction would stop and LCDM would send no more RSP. When there is no response, RSP would be also sent 3 times until TIMEOUT.

2.3 Definition of Timings

Each FRAME defines Timings as below.

2.3.1 TIMEOUT in basic communication FRAME

EOT or SOH	I D	S T X	C M D	DATA	E T X	B C C
------------------	--------	-------------	-------------	------	-------------	-------------



The TIMEOUT in communication FRAME is defined the duration from EOT/STX to

BCC

2.3.2 Response Timings to basic communication FRAME

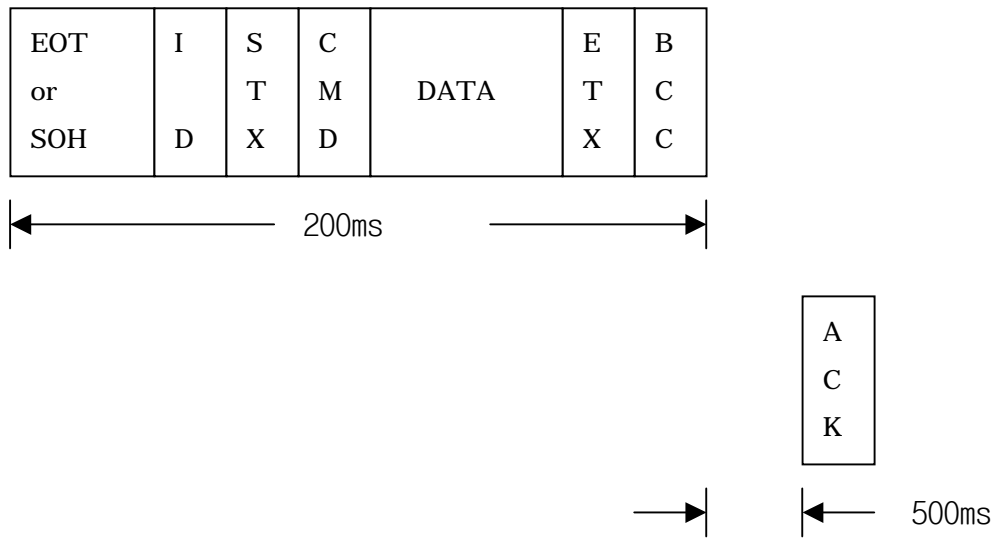

2.3.3 Response TIMEOUT to COMMAND

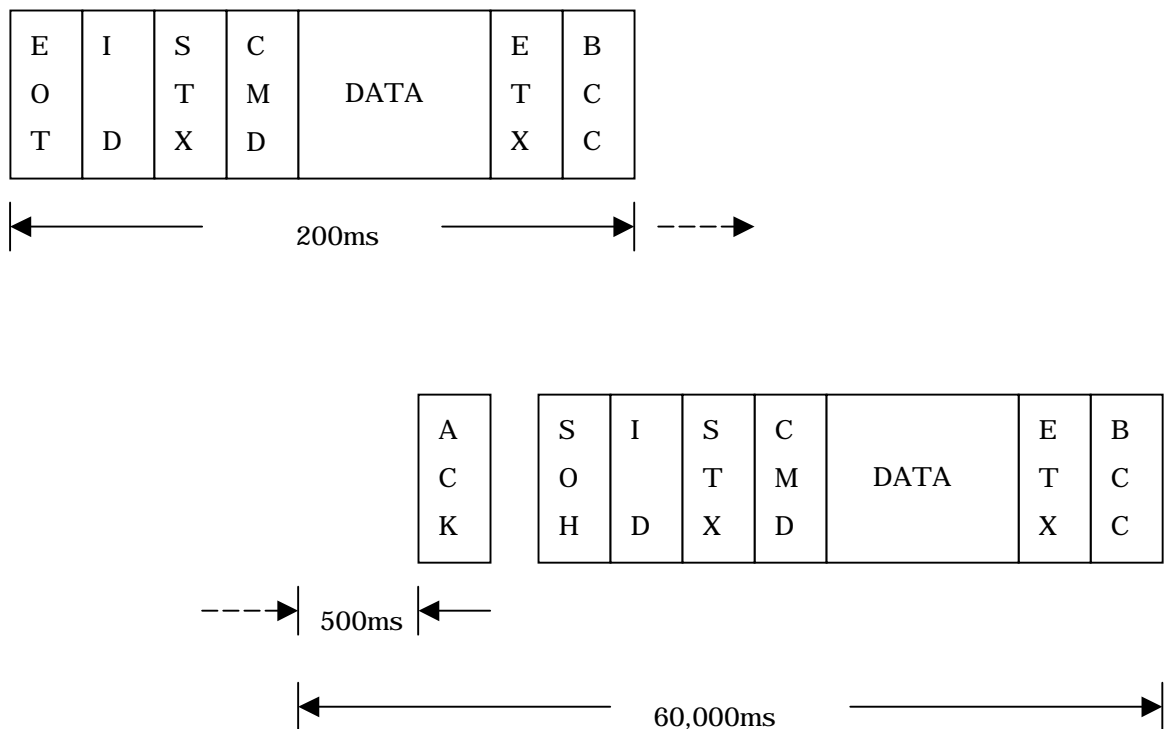

2.4 COMMAND FORMAT

The COMMAND(or CMD) is the data frame from HOST to MODEL 1000.

EOT
ID
STX
COMMAND
10's of the requested bills (ASCII)
1,s of the requested bills (ASCII)
ETX
BCC

2.4.1 COMMANDS

CODE	MNEMONIC	COMMENTS
0x44H	PURGE	To purge the unit (To check the operation of the unit by purge of the unit and clear path by passing notes to reject tray)
0x45H	DISPENSE	To dispense bills in the cassette (The requested number of notes to dispense is memorized and send the data to MODEL 1000)
0x46H	STATUS	To call for the current status of the unit and to send RESPONSE of the result to detect troubles mechanism in the format of code
0x47H	ROM VERSION	To ask for ROM version
0x76H	TEST DISPENSE	To reject the one bills in the cassette to the reject tray

2.4.2 Each COMMAND Format

A. Purge (0x44H)

04H (EOT)
50H (ID)
02H (STX)
44H (Purge)
03H (ETX)
XXH (BCC)

B. DISPENSE (0x45H)

04H (EOT)
50H (ID)
02H (STX)
45H (Upper dispense)
XXH (ASCII: '0' ~ '6')
XXH (ASCII: '0' ~ '9')
03H (ETX)
XXH (BCC)

→ 10's of the requested bills
 → 1's of the requested bills

Requested bill count → 1 ~ 60

< EX >

When the user instructs the LCDM to dispense 10 bills from the cash cassette, the command should be as follows.

04H	50H	02H	45H	31H	30H	03H	BCC
				↓	↓		
				10's	1's		
				('1')	('0')		
				9/17			

C. Test Dispense (0x76H)

04H (EOT)
50H (ID)
02H (STX)
76H (Test Dispense)
03H (ETX)
XXH (BCC)

D. STATUS (0x46H)

04H (EOT)
50H (ID)
02H (STX)
46H (Status)
03H (ETX)
XXH (BCC)

E. ROM VERSION (0x47H)

04H (EOT)
50H (ID)
02H (STX)
47H (Rom version)
03H (ETX)
XXH (BCC)

2.5 RESPONSE Code Format

The RESPONSE (or RSP) is the data frame from MODEL 1000 to HOST.

SOH
ID
STX
CMD CODE
10's of the dispensed bills in the CHK sensors
1's of the dispensed bills in the CHK sensors
10's of the dispensed bills in the EXIT sensor
1's of the dispensed bills in the EXIT sensor
ERROR CAUSE
Current status of cash cassette
10's of the rejected bills
1's of the rejected bills
ETX
BCC

2.5.1 ERROR Format

ERROR Code informs HOST of the information of troubles when the normal stopping doesn't happen and an error occurs in dispensing.

- ERROR CODE Format
ERROR CODE is configured by 1 byte.
- ERROR CODE Index

Code	Meaning
30H	Good
31H	Normal stop
32H	Pickup error
33H	JAM at CHK1,2 Sensor
34H	Overflow bill
35H	JAM at EXIT Sensor or EJT Sensor
36H	JAM at DIV Sensor
37H	Undefined command
38H	Bill- End
3BH	Note request error
3CH	Counting Error(between DIV Sensor and EJT Sensor)
3DH	Counting Error(between EJT Sensor and EXIT Sensor)
3FH	Reject Tray is not recognized
41H	Motor Stop
42H	JAM at Div Sensor
43H	Timeout (From DIV Sensor to EJT Sensor)
44H	Over Reject
45H	Cassette is not recognized
47H	Dispensing timeout
49H	Diverter solenoid or SOL Sensor error
4AH	SOL Sensor error
4EH	Purge error (Jam at Div Sensor)

2.5.2 Each RESPONSE Format

A. Purge

01H (SOH)	
50H (ID)	
02H (STX)	
44H (Purge)	
XXH (ERROR CAUSE)	→ See 2.5.1
03H (ETX)	
XXH (BCC)	

B. Dispense

01H (SOH)

50H (ID)	
02H (STX)	
45H (Dispense)	
XXH (ASCII: '0' ~ '6')	→ 10's of the requested bills (CHK1,2 Sensor)
XXH (ASCII: '0' ~ '9')	→ 1's of the requested bills (CHK1,2 Sensor)
XXH (ASCII: '0' ~ '6')	→ 10's of the requested bills (EXIT Sensor)
XXH (ASCII: '0' ~ '9')	→ 1's of the requested bills (EXIT Sensor)
XXH (ERROR CAUSE)	→ See 2.5.1
30/31H (Status of Cassette)	
XXH (ASCII: '0' ~ '9')	→ 10's of the rejected bills
XXH (ASCII: '0' ~ '9')	→ 1's of the rejected bills
03H (ETX)	
XXH (BCC)	

Status of cash cassette is like this
30H → Enough Notes (Normal)
31H → Status of Near end

C. Test Dispense

01H (SOH)	
50H (ID)	
02H (STX)	
76H (Test Dispense)	
XXH (ASCII: '0' ~ '2')	
XXH (ASCII: '0' ~ '9')	
30H (ASCII: '0')	
30H (ASCII: '0')	
XXH (ERROR CAUSE)	14/17 → See 2.5.1
30/31H (Status of Upper Cassette)	
XXH (ASCII: '0' ~ '9')	→ 10's of the requested bills

D. Status

01H (SOH)	
50H (ID)	
02H (STX)	
46H (Status)	
30H	
XXH (ERROR CAUSE)	
XXH (SENSOR0)	→ See 2.5.1
XXH (SENSOR1)	→ See 2.5.3
03H (ETX)	→ See 2.5.3
XXH (BCC 01H ~ 03H)	

E. ROM VERSION

01H (SOH)	
50H (ID)	
02H (STX)	
47H (ROM version)	
'O'	
XXH (ASCII)	} ROM Version
XXH (ASCII)	
'T' 15/17	
XXH (ASCII)	} ROM Version
XXH (ASCII)	



Check Sum

2.5.3 SENSOR STATUS

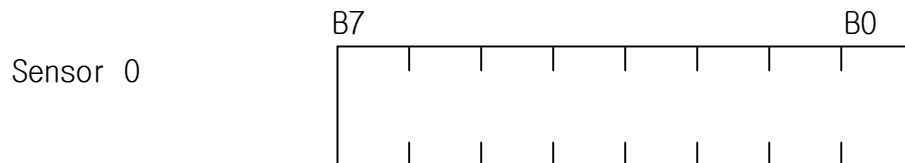

- B0 : CHK SENSOR 1
- B1 : CHK SENSOR 2
- B2 : DIV SENSOR 1
- B3 : DIV SENSOR 2
- B4 : EJT SENSOR
- B5 : EXIT SENSOR
- B6 : NEAREND0 SENSOR
- B7 : Always '1'

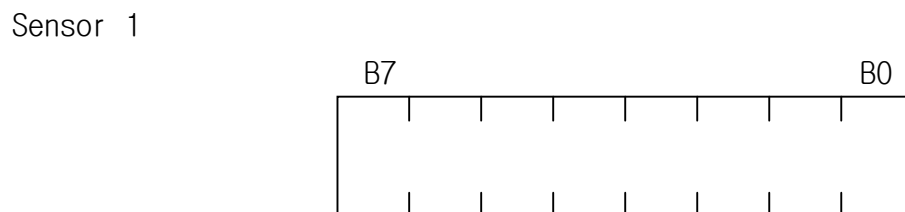

B0 : Reject tray S/W(0: Reject tray is on
1: No Reject tray)

B1 : CASSETTE SENSOR

B2 : SOL SENSOR

B3 : Not used

B4 : Not used

B5 : Not used

B6 : Not used

B7 : Always '1'