



Matrix USB

User Manual

Version 1.0

1.0 Introduction

The Matrix USB, the industries first USB enabled bill validator. The Matrix USB is available for all applications utilizing the PC USB port.

2.0 Communications

Matrix conforms to USB 1.1 specification issued by the USB Implementers Forum. It is a low speed device (1.5Mbit/sec) supporting EndPoint 0 (Interrupt IN/OUT and Setup) and EndPoint 1 (Interrupt IN only) reports. When Matrix is attached to the USB bus, an enumeration process takes place automatically by the Host Operation System. Upon successful enumeration, Matrix is registered as a HID-class device under the Human Interface Device category specified by the USB specification.

The Host sends poll to request information from Matrix at a periodic rate. Matrix answers to the poll and reports all the happening events. This poll rate must NOT faster than 20msec per poll. This is the minimum communication time with the Matrix. On the other hand, if the poll rate is too slow (eg. 500msec per poll), this will greater reduce the performance of Matrix in terms of acceptance rate.

2.1 GENERAL DATA

- Host - Refers to the application program or the computer system that handles the USB communication and interpretation of all the messages.
- Token - A collective term to refer to a banknote/barcode/coupon.
- Hub - Refers to an external hub for USB connections or the *Root Hub* built on the PC motherboard. In this document it refers to the port that Matrix connects to.
- Suspend mode - According to the USB 1.1 specification, all devices should enter a suspend (power saving) mode upon 3msec of inactivity of the USB bus. This includes the loss in communication with the Host or the Host Operation System disable the device etc. Matrix will enter this suspend mode after doing the followings:
 1. Disable Matrix.
 2. Return any bill that is currently undertaking.On exiting the Suspend Mode, Matrix will be reset by the inherent USB Bus reset. Any prior status / setup will be cleared and back to their default stage.
- Communication - Time out When the Host is not polling the Matrix for a time longer than 4 seconds, Matrix will return any bill held in escrow and will not take any bill. Matrix is disabled.
- Enumeration - When an USB device is attached to the Hub, the Host Operation System will start an enumeration process. During this process, information and capability of the device is sent to the PC. The Host Operation System will determine whether or not to configure

the device and register as an active device depending on the existing resources available in the system. The factors that may inhibit a device from being configured include the data bandwidth requested by the device, the CPU usage of the system and the traffic already in the USB bus etc. Only upon successful enumeration, the device is given a resource handle for application program to access. In MS Windows 9X/2K/Me, a registered USB device is shown under the *System Properties/Device Manager*.

Bus Address - According to the USB spec., up to 127 devices can be connected to the same USB bus on a single computer system. The attachment of the device should be done without user settings and be configured automatically by the Host Operation System. But in some situation, it is impractical or illogical to connect the same device more than one onto a single system. The limitation is due to the “fighting” for the same resources and interruption between the same kind of devices (For example: keyboard, mouse...).

For Matrix, it has the capability to identify itself among a multi-Matrix system. Matrix utilities a unique Address ID Setting to give itself a unique Bus Address for identification and for resources allocation. This Address ID is a proprietary value in the product and will not interfere the normal USB operation. By using different Address ID Settings, up to 4 Matrix can be attached on a single system simultaneously. Upon successful enumerations, each Matrix is assigned with different resource handle. The application program should be able to retrieve the different handles from the Operating System and communicate with Matrix independently. End user can easily identify each Matrix just by observing to the jumper setting.

Sequence No. - In USB development, it is a common issue that the application program cannot *see* a real time upstream message sent from the device. That is to say, all the upstream messages sent from the device are stored to the bottom of the Host computer buffer. Only by continual “popping” of the buffer will the latest message be able to be seen by the program. This leads to an unsynchronised situation in Matrix communication. When the Host polls Matrix for the most current status, the Host will always *see* the precedent message stored in the computer buffer. The Host has to keep on retrieving the buffer messages until the last message pops up to the top of the buffer.

In MS Windows 98 this buffer has a fixed storage of 2 messages. In MS Windows 98SE/2K/Me, the default number is 8. User can change this number with *SetNumInputBuffers* register. To cope with this variance of Operating Systems, Matrix incorporates with a message Sequence No. to keep track of the messages. This number is added to both the upstream and downstream messages for the detection of the correct sequence of the receiving message. The Host will keep polling for the same command until the Sequence No. received from Matrix is the same as the one sent out. On the other hand, Matrix will keep resending the same message until the Host changes the same Sequence No.

2.2 DOWNSTREAM MESSAGE FORMAT

Host-to-Matrix

Format: >> **Cmd Byte, Bill Field Data 1, Bill Field Data 0, Mode Bits, Sequence No.**

Cmd Byte - Control commands send to Matrix.

Bill Field Data 1 - Upper (8th – 14th) enabled Bill channels.

Bill Field Data 0 - Lower (1st – 7th) enabled Bill channels.

Mode Bits - Compatibility settings and other control commands.

Sequence No. - Host sequence number.

Example: **04 00 7F 00 02**

Accept escrowed token; Bill Channel Enable: 1st to 7th; Message Sequence=02

Cmd Byte

Bit 0-1 Set to 0. Reserved for future use.

Bit 2- Stack Control Bit. To tell Matrix to accept a token that is held in escrow position.
1 = Stack / 0 = Keep in escrow

Bit 3- Return Control Bit. To tell Matrix to return a token that is held in escrow position.
1 = Return / 0 = Keep in escrow

Bit 4 – 7 Set to 0. Reserved for future use.

Bill Field Data 1

Upper Bill Channel Enabling Bits. To turn on / off an individual channel of Matrix.

Bit 0- 8th Channel (1=Enabled / 0=Disabled)

Bit 1- 9th Channel (1=Enabled / 0=Disabled)

Bit 2- 10th Channel (1=Enabled / 0=Disabled)

Bit 3- 11th Channel (1=Enabled / 0=Disabled)

Bit 4- 12th Channel (1=Enabled / 0=Disabled)

Bit 5- 13th Channel (1=Enabled / 0=Disabled)

Bit 6- 14th Channel (1=Enabled / 0=Disabled)

Bit 7- Set to 0. Reserved for future use.

Bill Field Data 0

Lower Bill Channel Enabling Bits. To turn on / off an individual channel of Matrix.

Bit 0- 1st Channel (1=Enabled / 0=Disabled)

Bit 1- 2nd Channel (1=Enabled / 0=Disabled)

Bit 2- 3rd Channel (1=Enabled / 0=Disabled)

Bit 3- 4th Channel (1=Enabled / 0=Disabled)

Bit 4- 5th Channel (1=Enabled / 0=Disabled)

Bit 5- 6th Channel (1=Enabled / 0=Disabled)

Bit 6- 7th Channel (1=Enabled / 0=Disabled)

Bit 7- Set to 0. Reserved for future use.

If both Bill Field Data 1 and Bill Field Data 0 are set to 00h, Matrix is disabled.

Mode Bits

Set to 00h. Reserved for future use.

Sequence No.

Initiated by the Host. It starts from 00h and increments on successive messages. It rollovers at FFh and starts at 00h again. The Host should send the same message continuously until Matrix responds with the same Sequence No.

2.3 UPSTREAM MESSAGE FORMAT

Matrix-to-Host

Format: >> Status, Events, Expansion, Bill Field Data, Sequence No.

- Status - Current status of Matrix.
- Events - Events experienced by Matrix.
- Expansion - Reserved for future use. Always returns 00h
- Bill Field Data - Denomination channel. Binary Format.
- Sequence No. - Sequence No. as sent by the Host.

Example: 08 00 00 02 02
Stacked; Bill Channel 2 in concern; Message Sequence=02

Status

- Bit 0- Accepting (=1 if a token is taking in and before Escrow position).
- Bit 1- Escrowed (=1 if a token is in Escrow position).
- Bit 2- Stacking (=1 if a token is accepting and being stacked).
- Bit 3- Stacked (=1 if a token is successfully stacked. Credit is issued).
- Bit 4- Returning (=1 if a token is being returned by the Host).
- Bit 5- Returned (=1 if a token has been returned by the Host).
- Bit 6- Rejecting (=1 if a token is being rejected by Matrix).
- Bit 7- Rejected (=1 if a token has been rejected by Matrix).

Events

- Bit 0- Failure (=1 on any kind of failure).
- Bit 1- Power Up (= 1 on power up).
- Bit 2- Cashbox Full (=1 if the cashbox is full).
- Bit 3- Cheated (=1 if a cheat / stringing is detected).
- Bit 4- Bill Jammed (=1 if Matrix is jammed).
- Bit 5- Cashbox Present (=1 if the cashbox presents).
- Bit 6- Invalid Command (=1 if an invalid command is received).
- Bit 7- Set to 0. Reserved for future use.

Expansion

Reserved for future use. Always returns 00h.

Bill Field Data

Report of denomination channel that is under concerned. Binary format. Matrix can report up to 14 denomination channels under USB protocol.

Bit 3-0	0000 = None/unknown bill	1000 = 8 th bill type
	0001 = 1 st bill type	1001 = 9 th bill type
	0010 = 2 nd bill type	1010 = 10 th bill type
	0011 = 3 rd bill type	1011 = 11 th bill type
	0100 = 4 th bill type	1100 = 12 th bill type
	0101 = 5 th bill type	1101 = 13 th bill type
	0110 = 6 th bill type	1110 = 14 th bill type
	0111 = 7 th bill type	

Bit 7-4 Set to 0. Reserved for future use.

Sequence No.

Matrix will give the same Sequence No. received from the Host for synchronization purpose.

3.0 ELECTRICAL HOOKUP

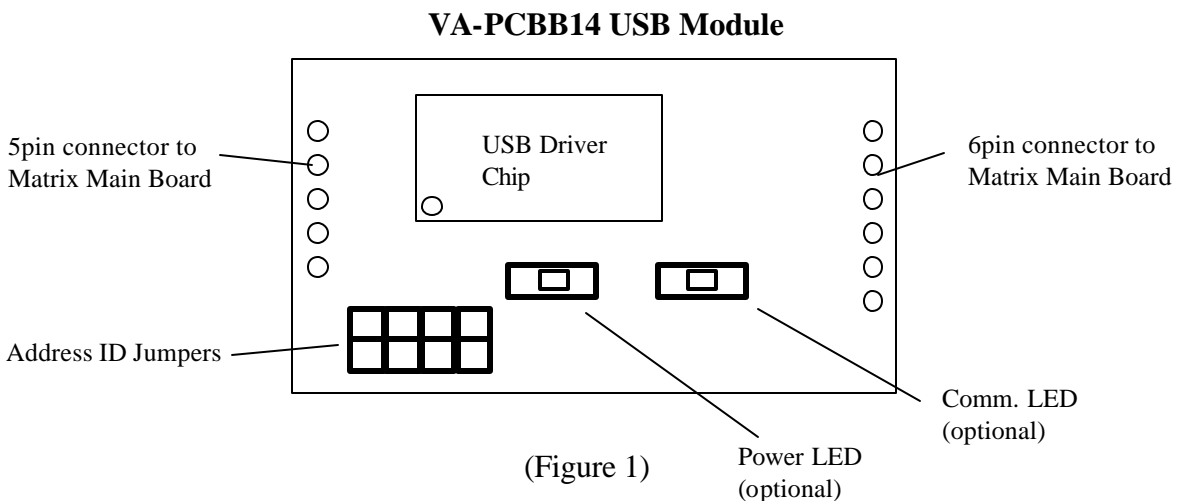

DC12V model only

5pin / 6pin Connector to Matrix Main Board

- Observer polarity while inserting module onto Main board.

USB Driver Chip

- Communication CPU to handle USB traffic.

Power LED

- A Green LED to show presence of power.

Comm. LED

- A Red LED to show communication with Host system.

Address ID Jumpers

- A selection of 4 ID positions. Each Matrix on a single Host system must have a unique Address ID.

3.1 Address ID configuration

The Address ID configuration jumpers locate on the lower left corner. There are 4 different settings for the 4 distinctive address IDs. Choose the address that is unique in the system and place the jumper in the corresponding position. See figure 2.

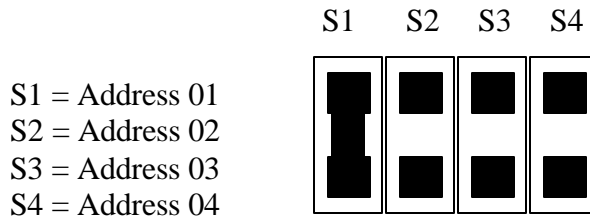

(Figure 2)

Observe the following procedure when doing the change.

1. Stop all USB communication on the Host.
2. Unplug the power cable to Matrix.
3. Disconnect Matrix from the Hub / USB bus.
4. Remove the front bezel cover of Matrix and locate the Address jumpers inside the cabin.
5. Change the jumper setting according to your needs. The default one is at Address 01. Do not set more than one device with the same address on a single system.
6. Replace the bezel cover.
7. Reattach the power cable and USB cable.
8. Start the USB communication on the Host. Matrix should show a new Address ID.